

MODEL NO.	OVERALL FRAME WIDTH (A)	CLEAR DOOR OPENING WIDTH (B)	BREAKOUT OPENING WIDTH (C)	ACTIVE LEAF WIDTH (D1)	SIDELITE WIDTH (D2)	ROUGH OPENING WIDTH (E)
5954-8	96" [2438.4]	44 1/2" [1130.3]	89" [2260.6]	49" [1244.6]	45 5/8" [1158.9]	96 1/2" [2451.1]
5954-8-6	102" [2590.8]	47 1/2" [1206.5]	95" [2413.0]	52" [1320.8]	48 5/8" [1235.1]	102 1/2" [2603.5]
		A/2 - 3 1/2" A/2 - [88.9]	A - 7" A - [177.8]	A/2 + 1" A/2 + [25.4]	A/2 - 2 3/8" A/2 - [60.3]	A + 1/2" A + [12.7]

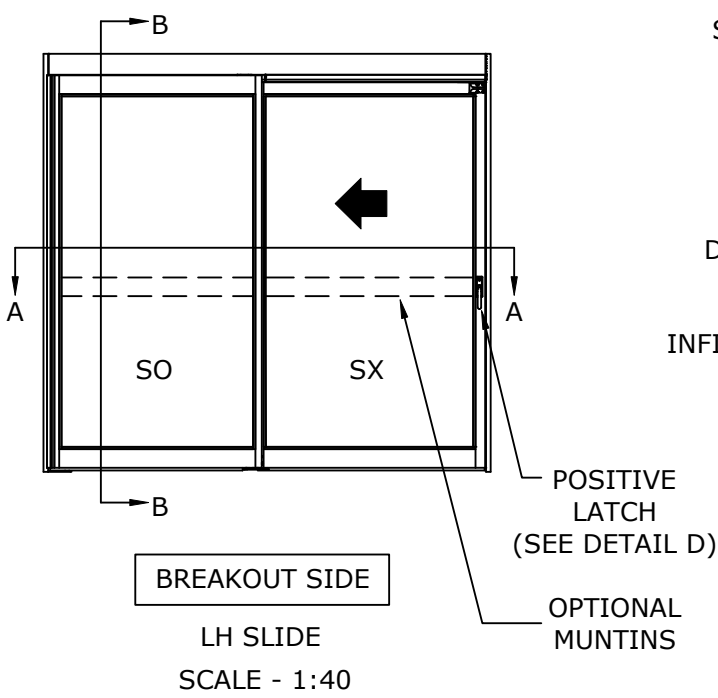

* SEALS: FACTORY APPLIED SEALS USED ON THIS SYSTEM TO SLOW OR RESTRICT PASSAGE OF SMOKE COMPLIES TO ONE OR MORE OF THE FOLLOWING REQUIREMENTS: UL1784, ANSI/NFPA105 2007, UBC7-2, PART11, B5476, UL10B, UL10C, UBC7-2 PART 1 & B5476.

- NOTES:**
 STANDARD PACKAGE CONSISTS OF:
- STANDARD FINISH: CLASS 1, .018MM, CLEAR- AA-M12C22A41
 - NARROW STILE RAILS
 - 1/4" GLASS STOPS AND BLOCKS
 - NURSE ASSIST MAGNETIC CATCH (SX PANEL)
 - FLUSHBOLT (SO PANEL)
 - 1" WIDE JAMBS
 - MANUAL POSITIVE LATCHING (RD-222)
 - CONCEALED SWEEPS (RD-4)
 - SMOKE RATED SEALS

- OPTIONS AVAILABLE:
- SPECIAL FINISHES
 - SELF-CLOSING (RD-2)
 - MAGNETIC HOLD OPEN (RD-3)
 - ANTI-STATIC (RD-6)
 - CLOSE DAMPENING DEVICE (RD-9)
 - PACKAGE WILL ACCEPT UP TO 1 1/4" [31.8] INSULATED GLASS (RD-13)
 - 7" & 10" BOTTOM RAILS (RD-14)
 - MUNTINS (RD-14)
 - ANTI-MICROBIAL COATING

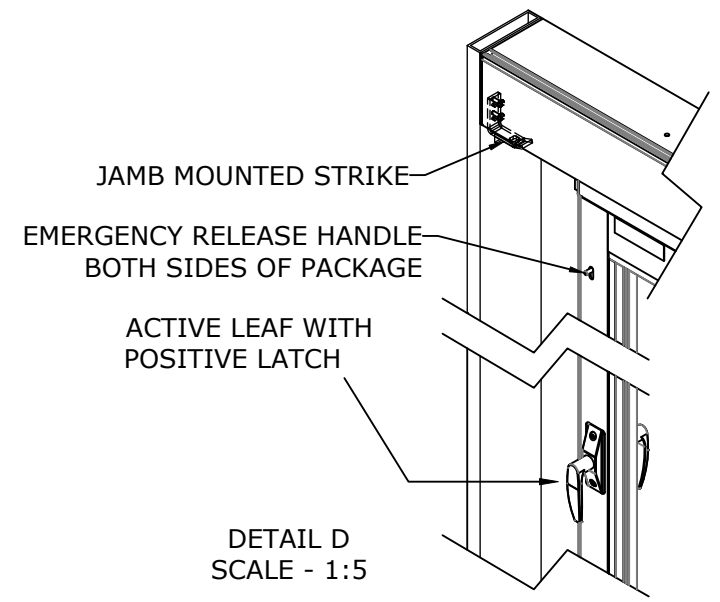
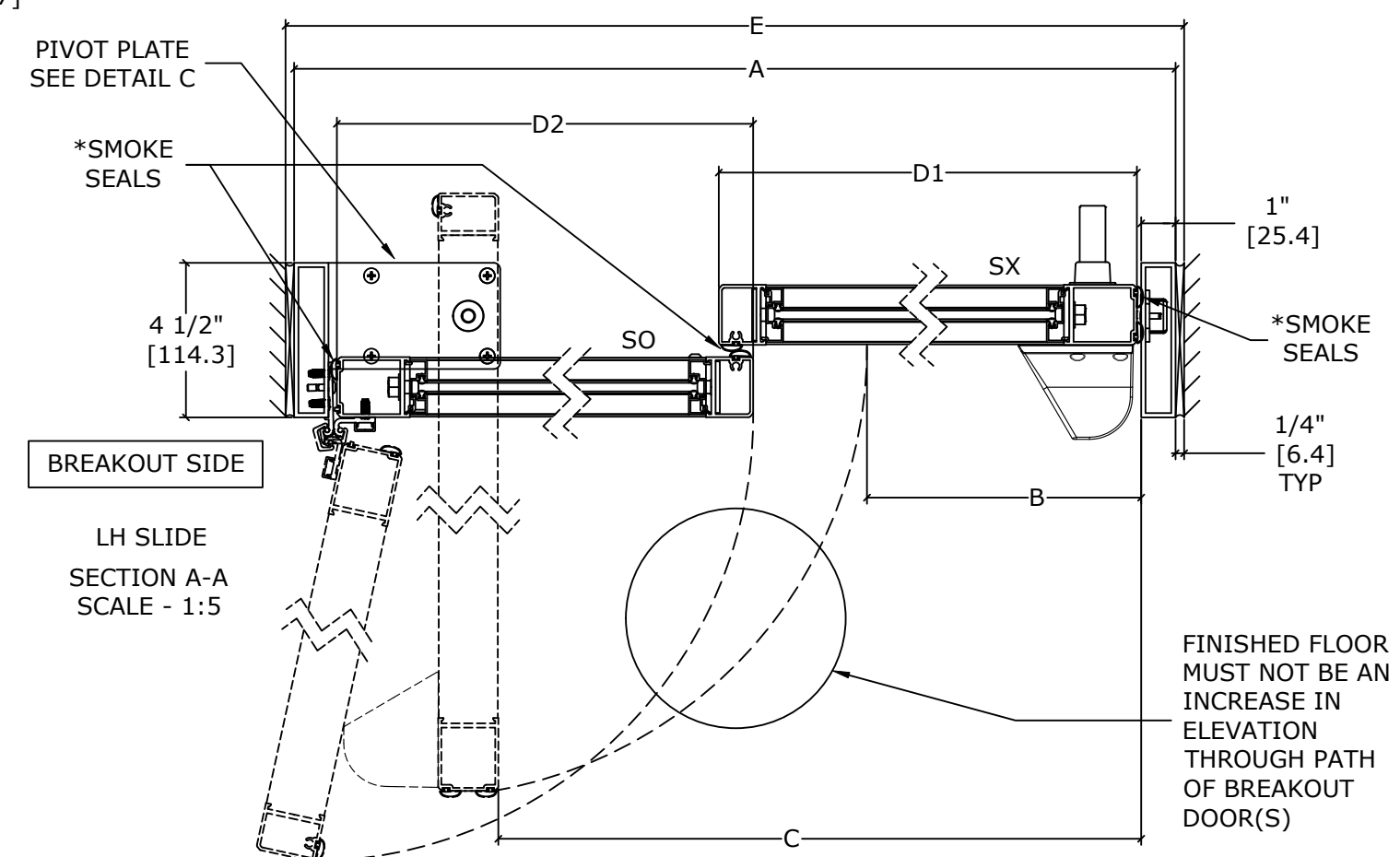
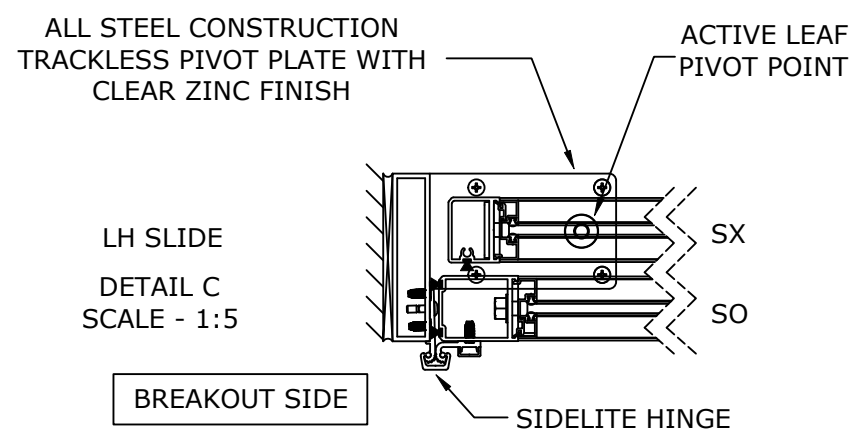
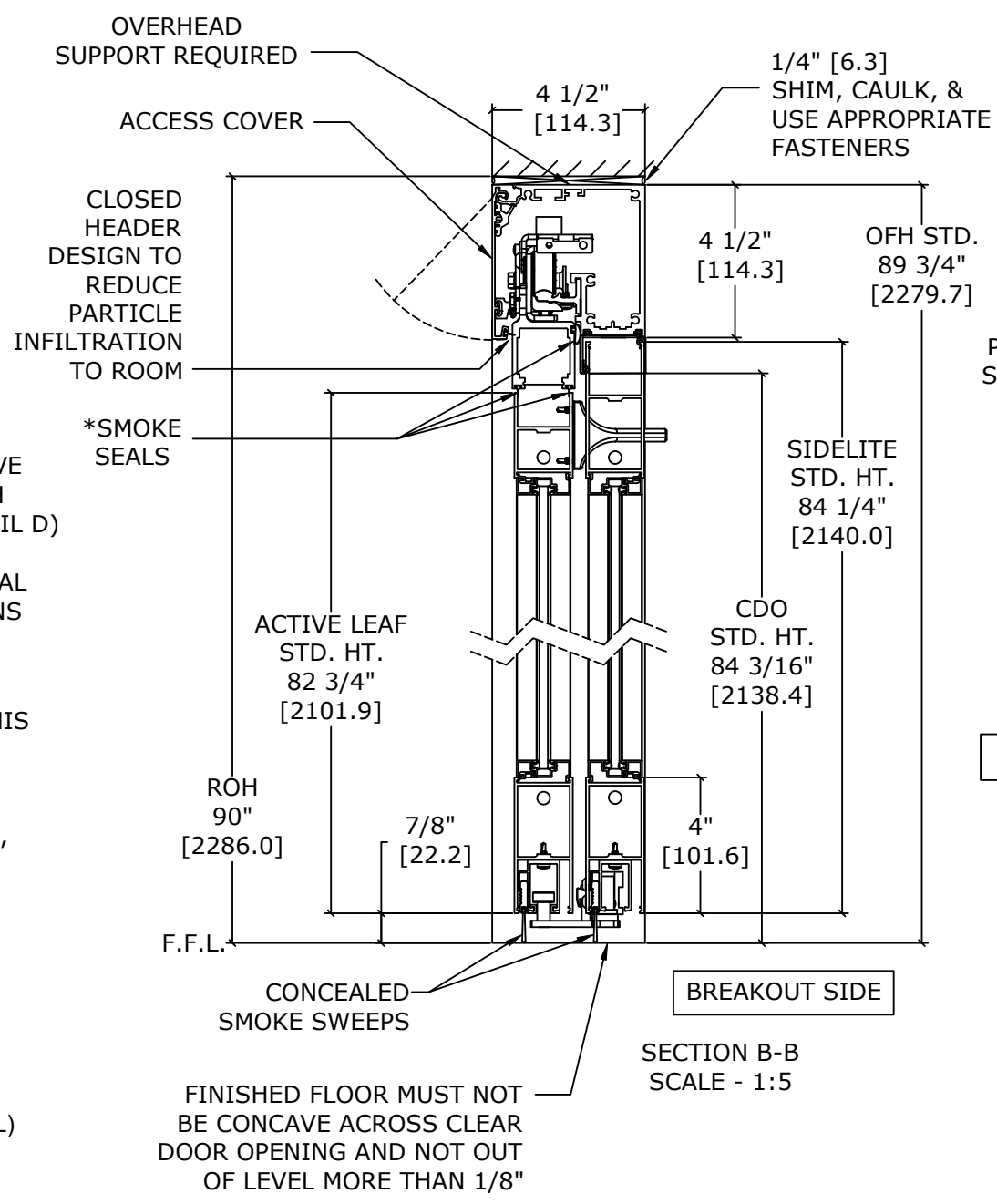

* DOORS WILL ONLY BREAK OUT IN FULLY OPEN POSITION.

REFER TO RELEVANT [LOCAL, STATE, NATIONAL, OR AHJ] BUILDING CODE FOR MIN DOOR HEIGHT & MIN/MAX WIDTH ALLOWABLE FOR EGRESS REQUIREMENT IN CONJUNCTION WITH TABLE.

DWG NO. ACH-1608745

DRN BY	DBN	DATE	10/02/25	CHK BY	CBG	DATE	10/02/25	REV.	1.0	DATE	10/02/25
--------	-----	------	----------	--------	-----	------	----------	------	-----	------	----------