

1 Prepare unit for mounting.

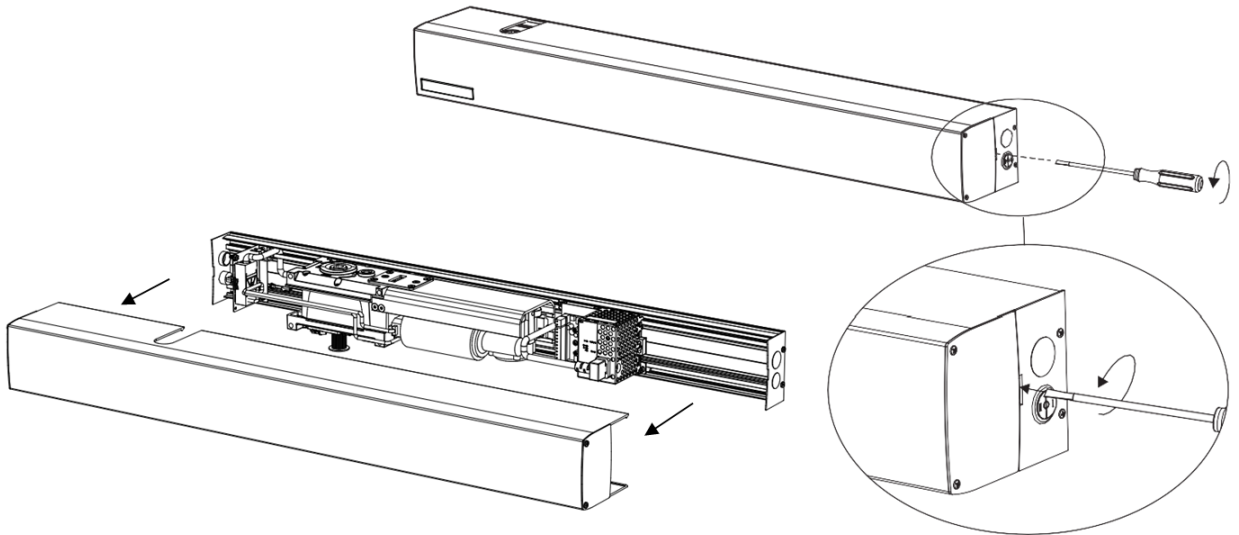

Mark spindle center on the bottom edge of header before removing. This will help you to relocate the Motor/Gearbox when time for reinstalling.

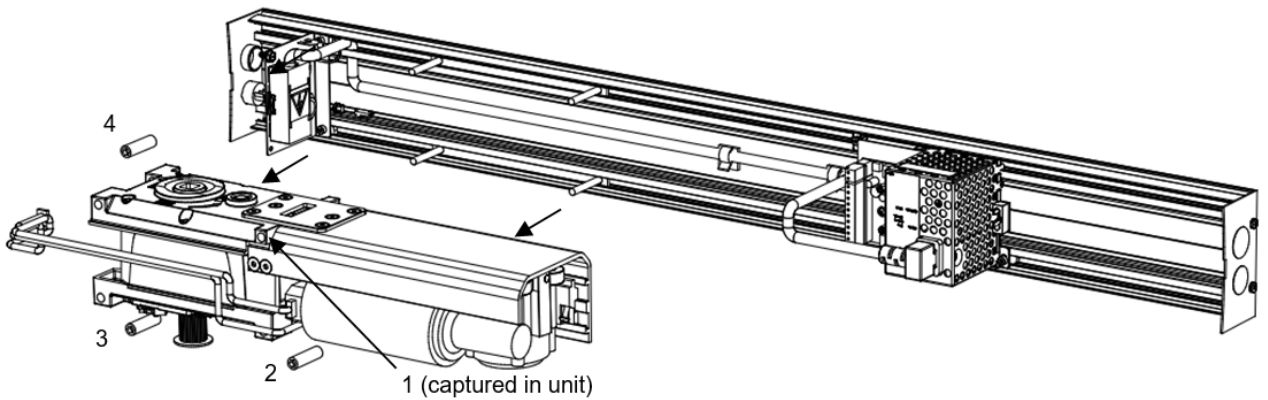

1 of 6



2 Mount header backer plate.

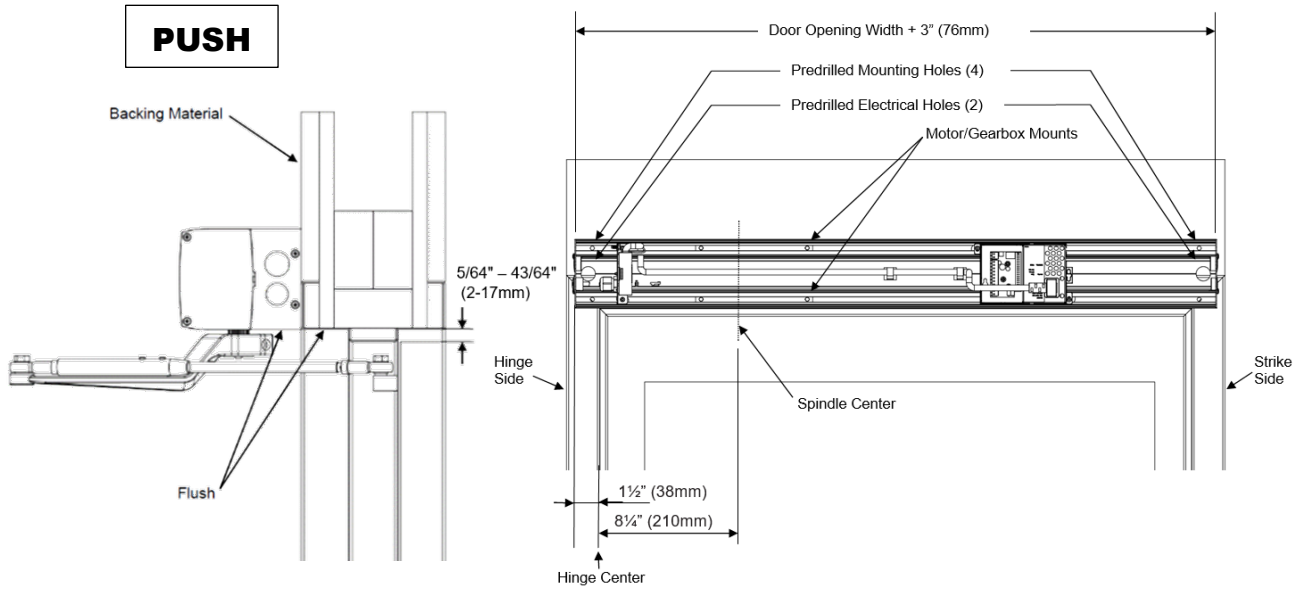

PULL



The header must be securely anchored to the frame and wall. It must be strong enough to support 200 lbs. (90kg), place anchors 12" to 16" (305mm to 406mm) apart.

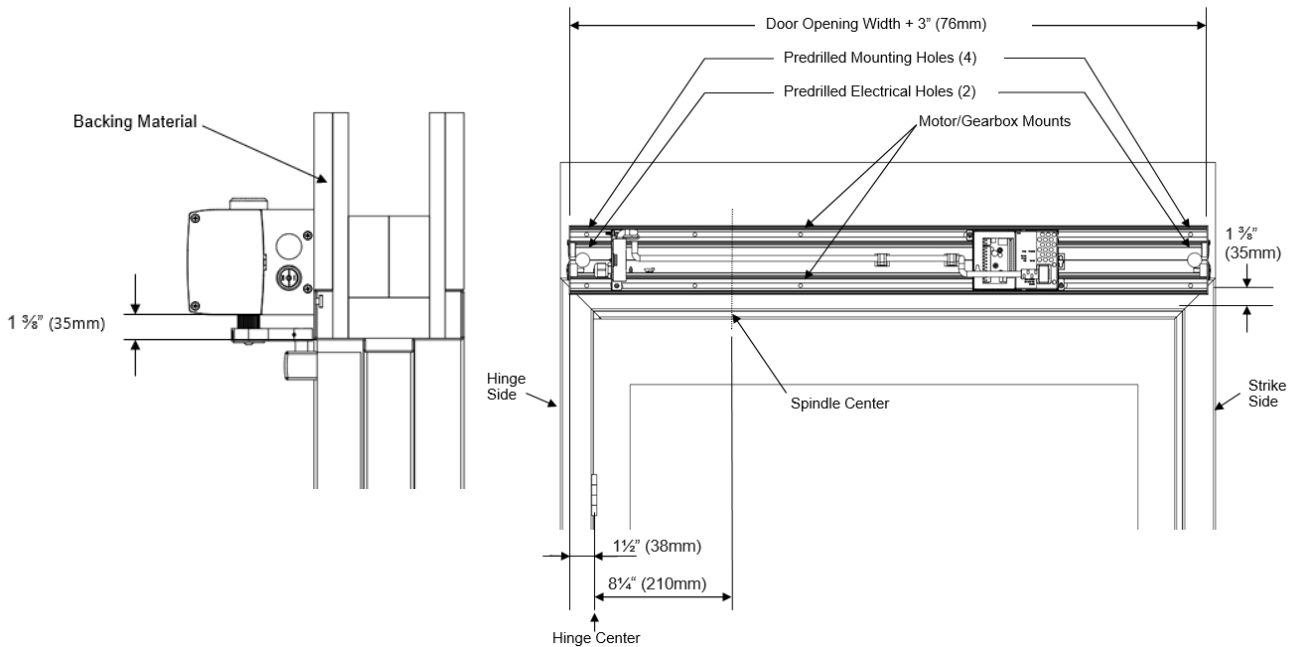

3 Connect power.

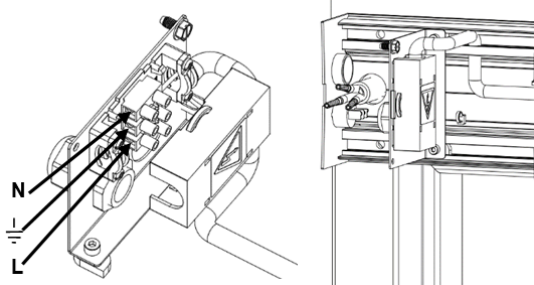

The mains connection must remain isolated until the wiring is completed.



④ Change unit configuration.

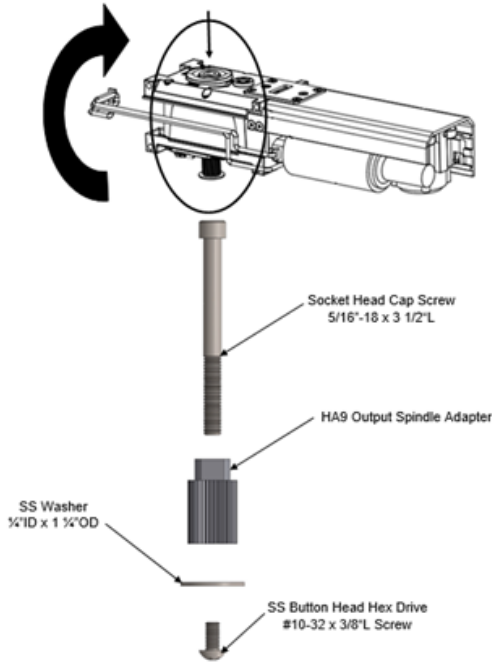

Note:
HA9 Output Spindle Adapter can be removed and the motor/gearbox rotated 180 degrees (flipped) for switching from Push to Pull Requirements.

Place arm on unit at center line of unit. Then rotate the arm -5° (while holding the unit) so you can remove the two screws that hold the Lock Kick / Stop Block Assembly. The Arm is under spring load so do not release. After removing Lock Kick / Stop Block Assembly allow the arm to gently rotate to remove the spring load.]

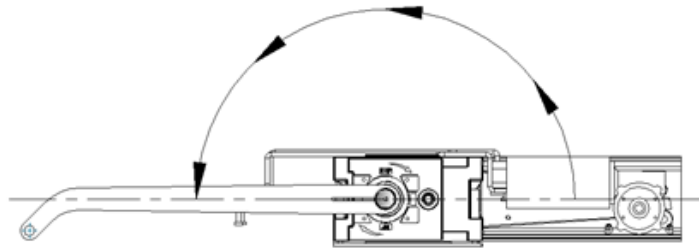
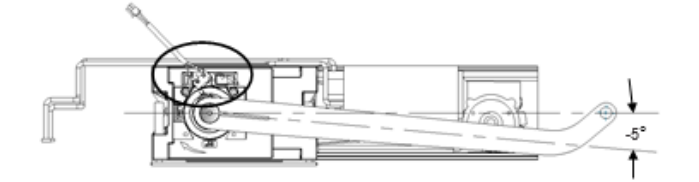

Reinstall the Lock Kick / Stop Block Assembly in the alternate location (180° from its original position).

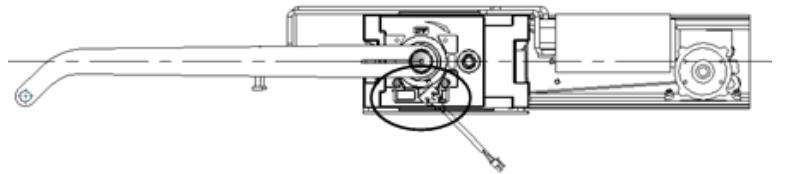

Rotate arm 180° (while holding the unit) so you can reload the spring tension and reposition stop arm.

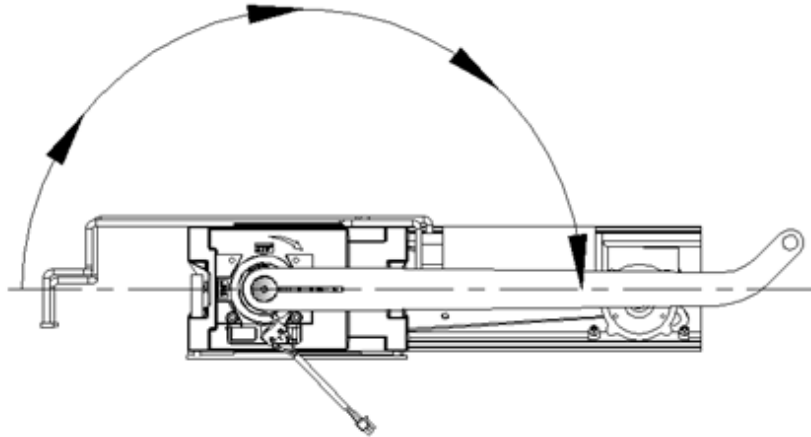

While holding the arm in position, gently lift the lock kick cam and the door stop arm, rotate the door stop arm so it is against the stop block and press it down so it locks into the splines. When you release your grip on the arm the stop block should keep it from rotating. Now rotate the lock kick cam so that it is positioned under the lock kick micro switch and press it down so it locks into the splines.

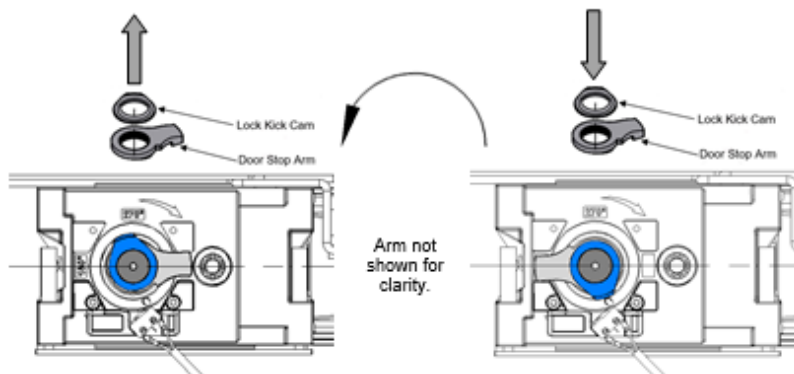

5 Reinstall motor/gearbox.

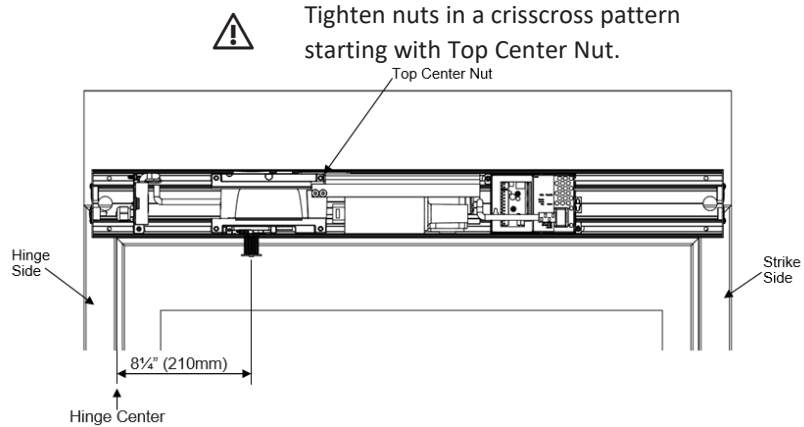
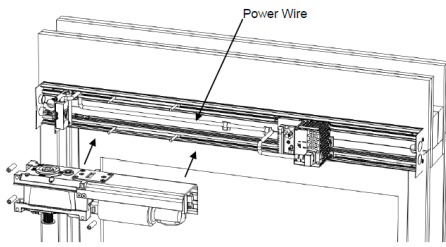

Tighten nuts in a crisscross pattern starting with Top Center Nut.



Spindle must be located as shown.

6 Install arm.

PUSH

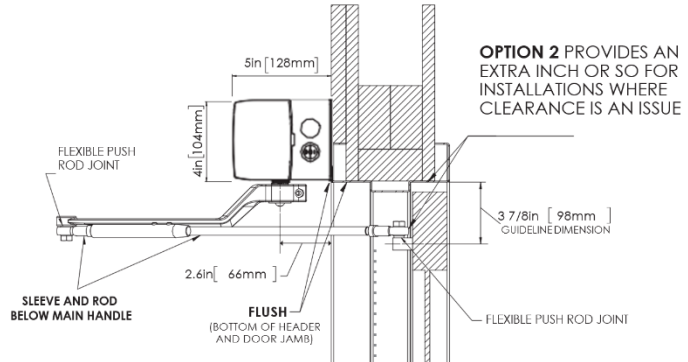
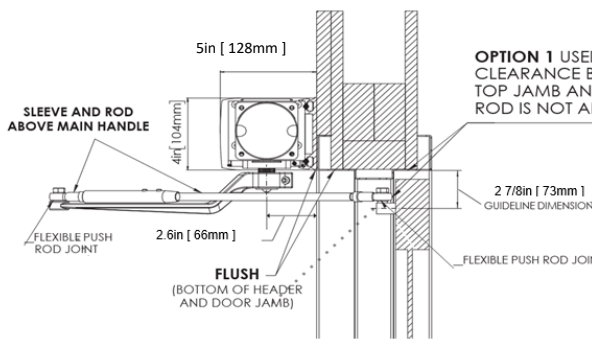

Measure from hinge center to first hole on Door Shoe.

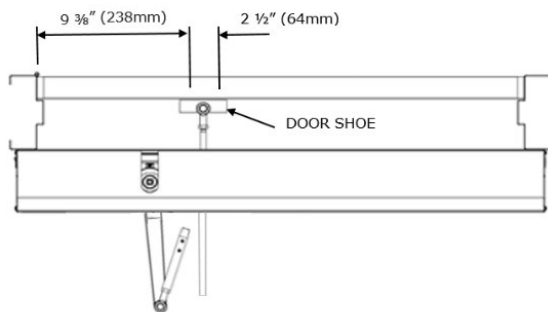

Rod must extend 1" (25.4mm) past 2nd setscrew.

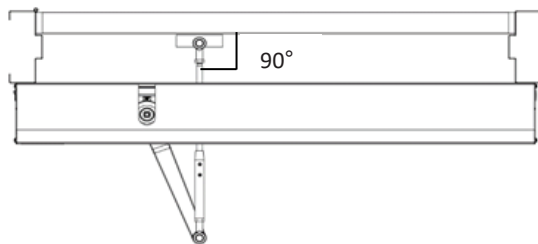
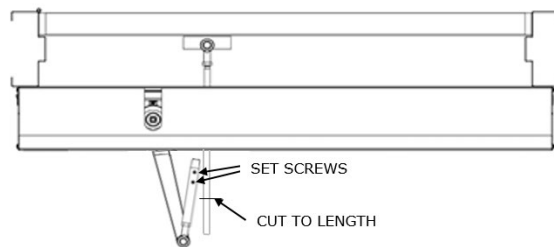

The Rod to be perpendicular to the door and the Main Arm at 80° at closed position.



PULL

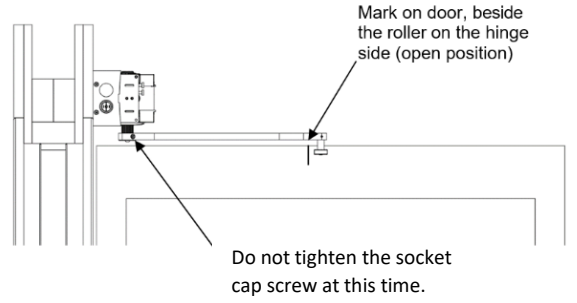
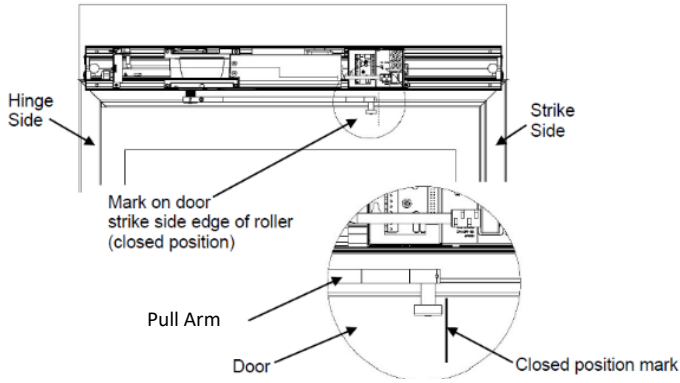

Determine spacer requirement and orientation. Max reveal is $2 \frac{3}{8}$ " (60mm).

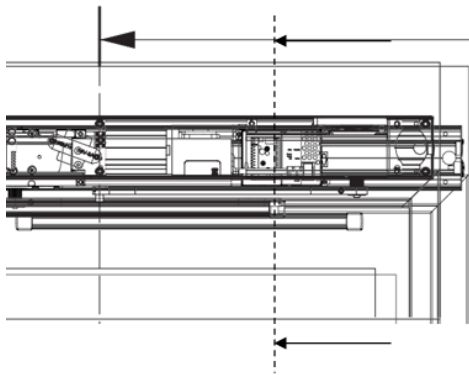
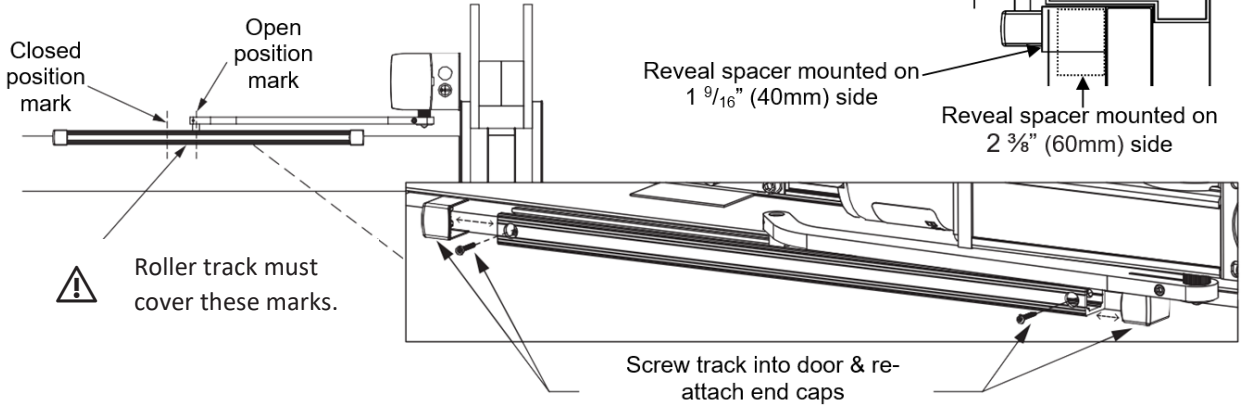

ROLLER TRACK CROSS SECTION

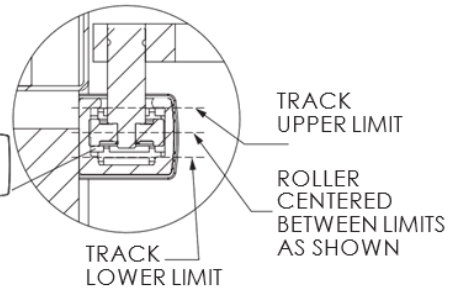

SET SCREW DETAIL

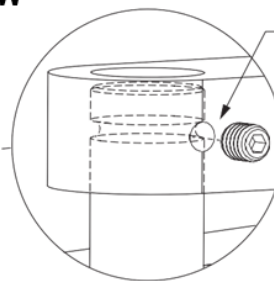
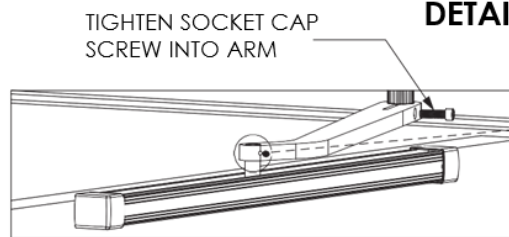

7 Tune operator.

7a



7b Arm system setting

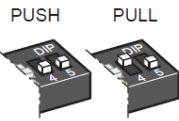

7c

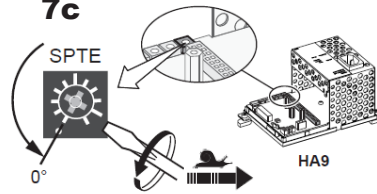

7d

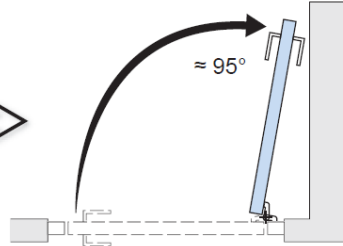
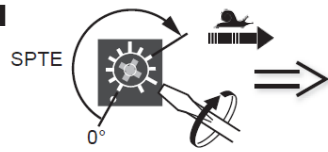

7e

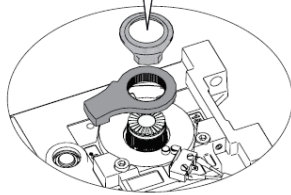

7f

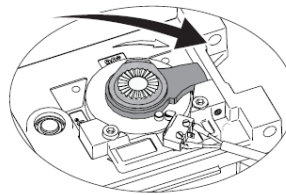

7g

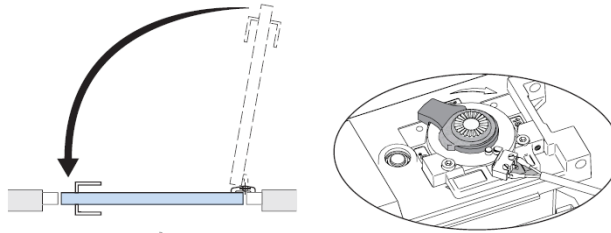
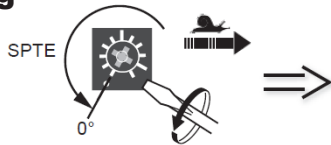

7h

Lock kick at power failure

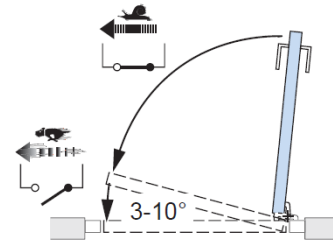
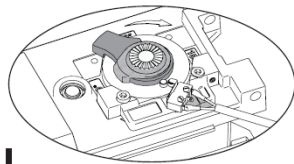

7i

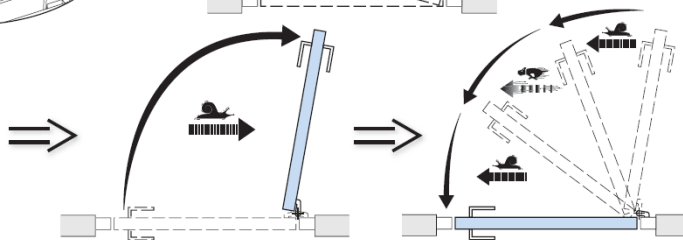
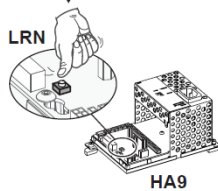

8 Install header cover.

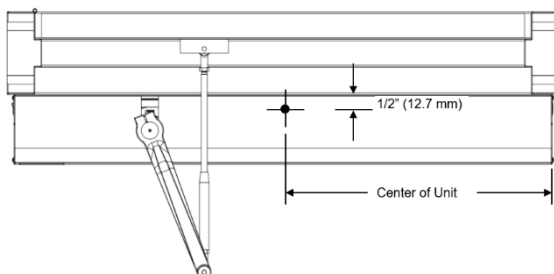

Use a #8-18 x 1/2" L Self-Drilling Screw.

